



 **YAMAMOTO**

**HRB-1000**

**HRB-1700**

**YTB-1120**



# WHAT IS YAMAMOTO HYDRAULIC ROCK SPLITTER?

The use of explosives are the most common methods for excavation of hard rock. However, restrictions on blasting are increasingly strict and requires permits and inspections. In densely populated or otherwise sensitive areas, blasting may be completely banned due to concerns about vibrations, flyrock or other safety aspects.

Yamamoto Hydraulic Rock Splitter was designed as a mean to excavate hard rock without any concerns for vibrations, flyrock or noise. The method is based on the traditional wedge and feather method but is using hydraulic power to split the rock instead of impact force.

The splitter is normally mounted on a normal excavator and uses the hydraulic power of the carrier. But it can easily be used on a crane or tailor made carrier, all depends on the type of project. The simple installation method allows it to be moved from carrier to carrier without any major modifications so the same splitter can be used in many different types of project.

For large volume rock excavation, in hard rock, there is simply no mechanical method more efficient, safe and quiet than Yamamoto Hydraulic Rock Splitter. This is the reason it has been used in worldwide in some of the most challenging and important construction projects.

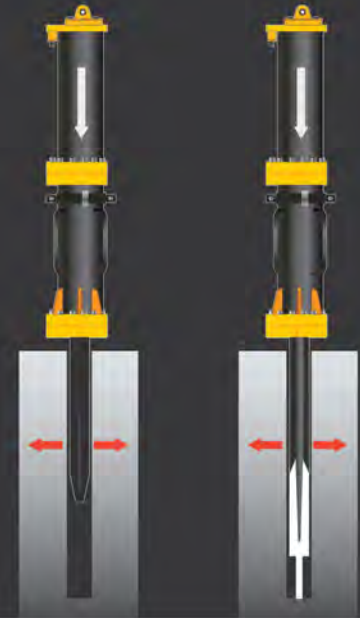

## Advantages of Yamamoto Hydraulic Rock Splitter

Yamamoto Ultra Large Rock Splitter has been developed and refined over the past 30 years to provide superior quality and maximum output. Key features include:



### PRODUCTIVITY

With the largest splitter on the market, it also offers the highest productivity. With larger wedge you can increase the spacing between holes and do deeper with each split.



### ROBUSTNESS

The Yamamoto rock splitter is designed with minimal number of parts, utilising the pressure of the excavator to avoid boosters, and manual greasing to allow for greasing all the way out to the tip of the wedges, there is nothing that can fail.



### DURABILITY

All components are designed with large safety margins and precise finishing allowing the splitter to run trouble free for a long time. Many customers can use the splitter for a year without any service or repairs.

## How does Yamamoto Rock Splitter work?

The working principle of Yamamoto rock splitter is based on two counter wedges inserted in a pre-drilled hole. A hydraulic cylinder pushes out a centre wedge between the counter wedges to spread them apart and the rock is forced to crack.



### 1st Step:

Insert half of the total length of wedge and operate the Yamamoto splitter to split.

### 2nd Step:

Then insert about  $\frac{3}{4}$  of the total length of the wedge to split again.

### 3rd Step:

Finally, insert the total length of the wedge and split to complete.

# TECHNICAL SPECIFICATIONS

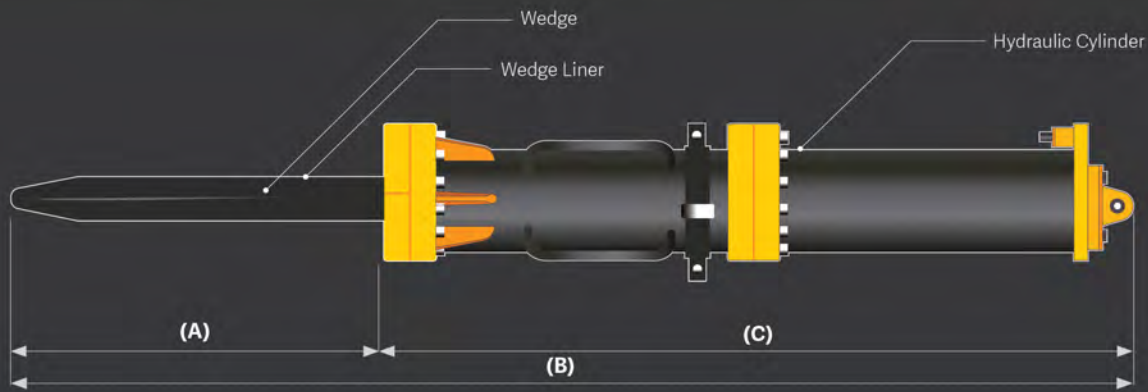

Model	HRB-1000	HRB-1700
<b>Weight</b>	650 kg	1,500 kg
<b>Drill hole diameter*</b>	Ø 102 mm	Ø 127 mm
<b>Drill hole depth</b>	1,500 mm	2,500 mm
<b>Splitting force</b>	22 MN (2,250 ton)	34 MN (3,550 ton)
<b>Splitting distance</b>	25 mm	30 mm
<b>Wedge diameter</b>	Ø95 mm to 110 mm	Ø120 mm to 160 mm
<b>Wedge length (A)</b>	1,150 mm	1,850 mm
<b>Wedge length (B)</b>	3,000 mm	4,300 mm
<b>Wedge length (C)</b>	1,850 mm	2,450 mm
<b>Hydraulic pressure (min/max)</b>	320/500 bar	320/500 bar
<b>Split hole spacing</b>	500-700 mm	700-1,000 mm

\* Also available for 76 mm drill hole diameter

## YTB-1120 Arm-system

Total solution for horizontal application

YTB-1120 Arm-system is a complete solution for using HRB-1000 in a tunneling application. The arm-system incorporates a telescopic boom with side-angling for easy insertion of the wedge without having to move the undercarriage. Between there telescopic boom there is a rotator for controlling the splitting direction.



Can be mounted on any standard excavator to turn it into a splitting machine



Fast and accurate insertion of wedge with telescopic arm



Side-angling for covering the full face without repositioning the undercarriage



Integrated rotator with 360 degree rotation



## 1 Drilling

Drill the holes of  $\varnothing 102\text{mm}$  X 1.5m depth for Yamamoto HRB-1000 splitter, or  $\varnothing 127\text{mm}$  X 2.5m depth for HRB-1700 splitter using a large size hydraulic crawler drill or jumbo drill rig. We recommend drilling in a staggered pattern with 500 - 700mm of spacing between holes for the HRB-1000 and 700 - 1000mm for the HRB-1700, as illustrated in the diagram.

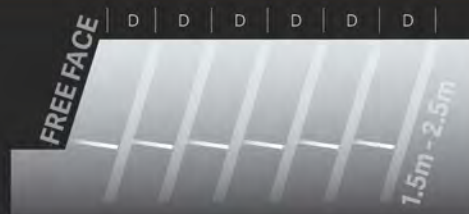

HRB-1000  
Distance (D) = 500-700mm  
Pitch (P) = 500-700mm  
Angle ( $\phi$ ) = 45-90°

HRB-1700  
Distance (D) = 700-1,000mm  
Pitch (P) = 700-1,000mm  
Angle ( $\phi$ ) = 45-90°



## 2 Splitting

Insert the wedge into the hole and split the rock. Position the wedge so that it is splitting towards the free face. To maximise the splitter's productivity, it is very important that the splitter is splitting towards a free face.



## 3 Secondary breaking and mucking

Break the already split rock into smaller pieces and remove it with a conventional excavator with a rock breaker. Removing the broken rock will keep the free face close to where the splitter is working. Secondary breaking and splitting can be conducted simultaneously.

Remove the muck using a hydraulic excavator, wheel loader or similar machine.





## 1 Drilling

Create a free face by drilling slots in the centre, bottom or periphery. Then drill split holes for the Yamamoto Splitter between the slots. Proper slot drilling involves drilling overlapping holes as bridges between the holes to allow the rock to maintain its structural integrity. A special attachment on the jumbo boom may be required for slot drilling. The photo and drawing below exemplify some recommended drilling patterns.

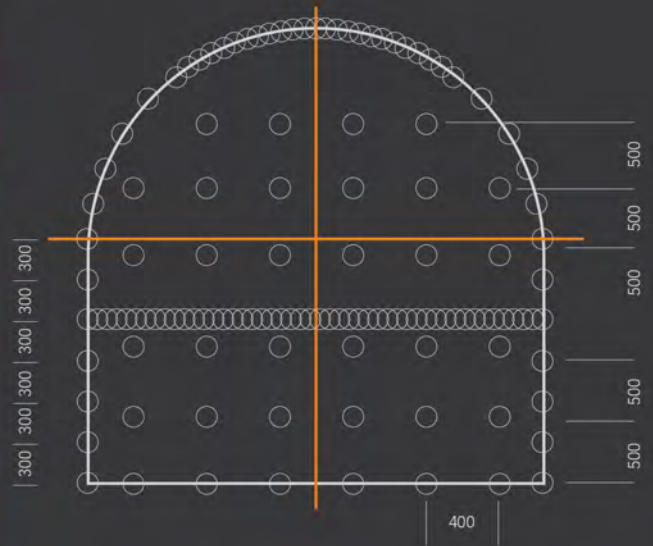

## 2 Splitting

Use a splitter mounted on a customised carrier equipped with telescopic boom and rotator. Start splitting the holes closest to the free face and aim at working from the bottom and up to allow support from gravity. Split in three steps by first inserting half of the total length of the wedge and split, then  $\frac{3}{4}$  of the total length and split and finally the full length of the splitter.



## 3 Secondary breaking and mucking

Break out the cracked rock into smaller pieces using a hydraulic breaker mounted on a conventional excavator. Work along the cracks caused by the Yamamoto Splitter. Use a muckling method that suits each project, typically done with a standard excavator.

Use a muckling method that suits each project, typically done with a standard excavator.

## ABOUT YAMAMOTO ROCK SPLITTER



The history of Yamamoto Rock Splitter started back in 1915 when the late Mr. Shuichi Yamamoto first started manufacturing spare parts for rock drills in the mountain village of Tojo in Central Japan. Over the years manufacturing expanded into rock drills, pneumatic drifters and hydraulic drifters. The drifters are supplied on a private label basis to reputed rock drill manufacturers such as Atlas Copco and Ingersoll Rand.

The first excavator mounted hydraulic rock splitter was supplied in 1981. Since then, we have supplied over 200 splitters worldwide. In 2010, a new International Sales and Logistics office was set up in Singapore to facilitate stocking and the delivery of splitter and spare parts. To better support European companies, a new center was established in the UK in 2016.

Even today, all manufacturing and product development still takes place in the original factory in Tojo, Japan. This allows us to maintain strict quality control and to build upon the 100 years of experience in manufacturing quality products.

## CONTACT US

### International sales and distribution

#### Yamamoto Rock Splitter International

320 Garratt Lane, London  
SW18 4EJ, United Kingdom

**Phone:** +44 20 3637 6430

**Fax:** +44 20 3603 5580

**Email:** [info@yamamotorocksplitter.com](mailto:info@yamamotorocksplitter.com)

### Factory

#### Yamamoto Rock Machine Co., Ltd.

424-1 Kawanishi, Tojo-Shobara,  
Hiroshima-Pref. 729-5125, Japan

**Phone:** +81 8477 22137

**Fax:** +81 8477 22140

### Your local dealer / distributor:

